

ACCESSORIES

The accessories listed in this manual are available at extra cost from your local dealer, Black & Decker Service Center, or by writing to Customer Services, Black & Decker (U.S.) Inc., 626 Hanover Pike, Hampstead, Md 21074

PRE PUNCHED ABRASIVE PAPER

Cat. No.	Grit	
59920	60	} Packs of 10.
59921	80	
59922	100	
59923	120	
59924	150	

Replacement Paper Punch Cat. No. 59928
Replacement Dust Bag Cat. No. 59929
Replacement Pad Cat. No. 59930

NOTE: Recommended accessories for this tool are listed in this manual and in Black & Decker Catalogs. The use of any other accessory may be hazardous.

LUBRICATION

Self lubricating bearings are used in the tool and periodic relubrication is not required. However, it is recommended that, once a year, you take or send the tool to a B&D Service Center for a thorough cleaning and inspection.

IMPORTANT

To assure product **SAFETY** and **RELIABILITY**, repairs, maintenance and adjustment, (including brush inspection and replacement) should be performed by Black & Decker Service Centers or other qualified service organizations, always using Black & Decker replacement parts.

COMMERCIAL/INDUSTRIAL USE WARRANTY

Black & Decker warrants this product for one year from date of purchase. We will repair without charge, any defects due to faulty material or workmanship. Please return the complete unit; transportation prepaid, to any Black & Decker Service Center or Authorized Service Station listed under "Tools Electric" in the yellow pages. This warranty does not apply to accessories or damage caused where repairs have been made or attempted by others.

BLACK & DECKER (U.S.) INC.

626 Hanover Pike, Hampstead, MD 21074 U.S.A.

(DEC '82)

Printed in France

735186



Black & Decker

OWNER'S MANUAL

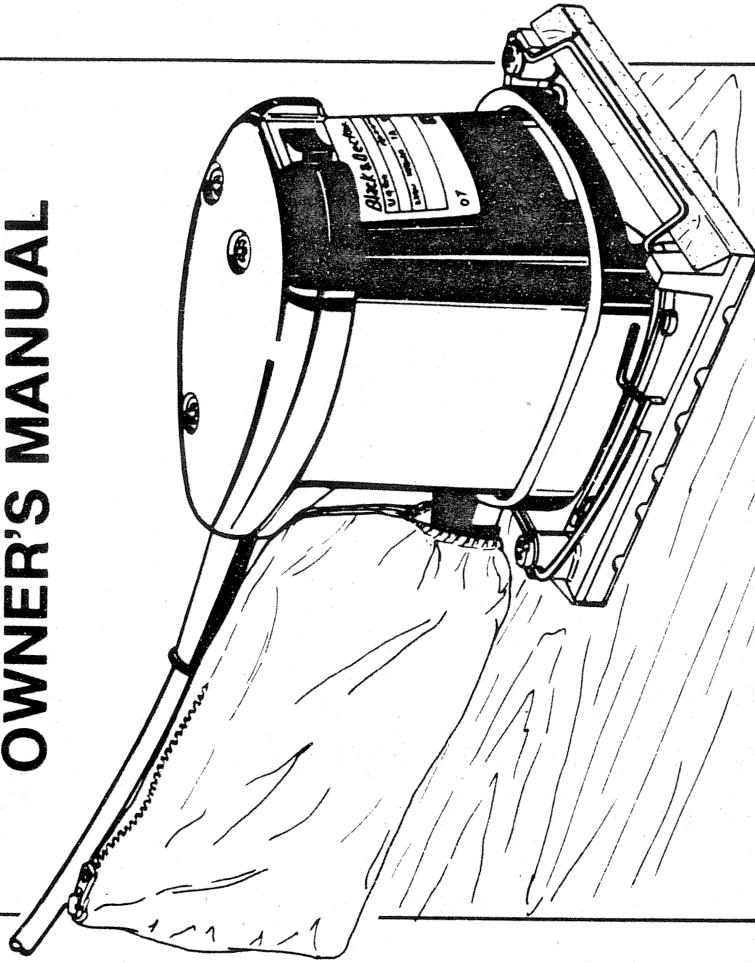

4010-10 Professional Palm Grip Finishing Sander

IMPORTANT SAFETY INSTRUCTIONS (FOR ALL TOOLS)

WARNING: When using Electric Tools, basic safety precautions should always be followed to reduce the risk of fire, electric shock, and personal injury, including the following:

READ ALL INSTRUCTIONS

1. KEEP WORK AREA CLEAN. Cluttered areas and benches invite injuries.
2. CONSIDER WORK AREA ENVIRONMENT. Don't expose power tools to rain. Don't use power tools in damp or wet locations. Keep work area well lit.
3. GUARD AGAINST ELECTRIC SHOCK. Prevent body contact with grounded surfaces. For example: pipes, radiators, ranges, refrigerator enclosures.
4. KEEP CHILDREN AWAY. All visitors should be kept away from work area. Do not let visitors contact tool or extension cord.
5. STORE IDLE TOOLS. When not in use, tools should be stored in dry, and high or locked-up place—out of reach of children.
6. DON'T FORCE TOOL. It will do the job better and safer at the rate for which it was intended.
7. USE RIGHT TOOL. Don't force small tool or attachment to do the job of heavy-duty tool. Don't use tool for purpose not intended, for example, don't use circular saw for cutting tree limbs or logs.
8. DRESS PROPERLY. Do not wear loose clothing or jewelry. They can be caught in moving parts. Rubber gloves and nonskid footwear are recommended when working outdoors. Wear protective hair covering to contain long hair.
9. USE SAFETY GLASSES. Also use face or dustmask if cutting operation is dusty.
10. DON'T ABUSE CORD. Never carry tool by cord or yank it to disconnect from receptacle. Keep cord from heat, oil, and sharp edges.
11. SECURE WORK. Use clamps or a vise to hold work. It's safer than using your hand and it frees both hands to operate tool.
12. DON'T OVERREACH. Keep proper footing and balance at all times.
13. MAINTAIN TOOLS WITH CARE. Keep tools sharp and clean for better and safe performance. Follow instructions for lubricating and changing accessories. Inspect tool cords periodically and if damaged have repaired by authorized service facility. Inspect extension cords periodically and replace if damaged. Keep handles dry, clean, and free from oil and grease.
14. DISCONNECT TOOLS. When not in use, before servicing, and when changing accessories, such as blades, bits, cutters.
15. REMOVE ADJUSTING KEYS AND WRENCHES. Form habit of checking to see that keys and adjusting wrenches are removed from tool before turning it on.
16. AVOID UNINTENTIONAL STARTING. Don't carry plugged-in tool with finger on switch. Be sure switch is off when plugging in.
17. OUTDOOR USE EXTENSION CORDS. When tool is used outdoors, use only extension cords intended for use outdoors and so marked.
18. STAY ALERT. Watch what you are doing. Use common sense. Do not operate tool when you are tired.
19. CHECK DAMAGED PARTS. Before further use of the tool, a guard or other part that is damaged should be carefully checked to determine that it will operate properly and perform its intended function. Check for alignment of moving parts, binding of moving parts, breakage of parts, mounting, and other conditions that may affect its operation. A guard or other part that is damaged should be properly repaired or replaced by an authorized service center unless otherwise indicated elsewhere in this instruction manual. Do not use tool if switch does not turn it on and off.
20. DO NOT OPERATE portable electric tools near flammable liquids or in gaseous or explosive atmospheres. Motors in these tools normally spark, and the sparks might ignite fumes.

FIG. 8

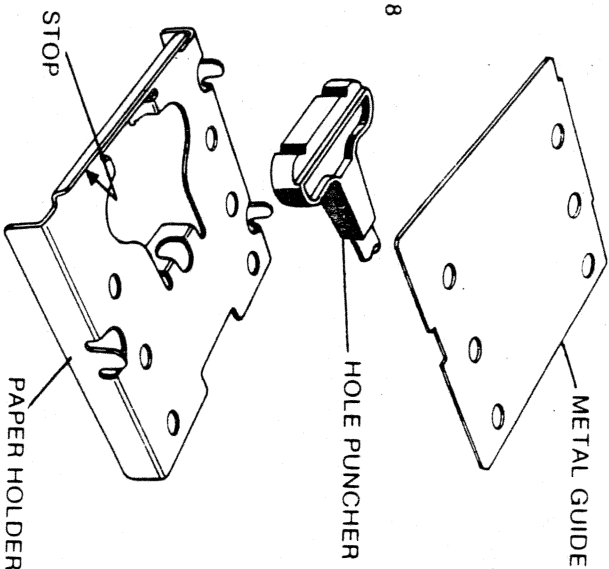

SANDING

It is not necessary to exert a lot of pressure on the tool when sanding horizontally. The weight of the sander itself is usually sufficient to ensure satisfactory results. Any excess will reduce its efficiency.

In order to obtain an optimum finish, it is essential to progressively reduce the grain size of the paper being used. With each change in grain size, it is recommended to sand at right angles in relation to the previous sanding. In order to obtain a perfect finish, after using a very fine-grained paper, we recommend wiping the work surface with a slightly damp rag and sanding again with the finest paper possible.

In order to obtain maximum dust collection, it is important to empty the dust bag frequently.

The rate at which the dust bag will fill up is largely dependent on the type of material being sanded and the size of grit used. A good rule of thumb is to empty the bag when it becomes about 1/3 full. So that the recovery bag can be thoroughly cleaned, it is washable and must be dried before replacing in sander.

TOOL CARE

Keep your machine as clean as possible by wiping with a clean cloth and occasionally blowing through with air.

Avoid overloading your sander. Overloading will result in a considerable reduction in speed and efficiency and the unit will become hot. In this event, run sander at a "no load" condition for a minute or two. This may be accomplished by holding unit away from work surface and allowing it to run "free speed."

SWITCH

To operate unit, press right side of rocker switch. A white mark should appear to indicate switch is in the "on" position. To stop unit, press left side of rocker switch. The white mark should no longer be visible.

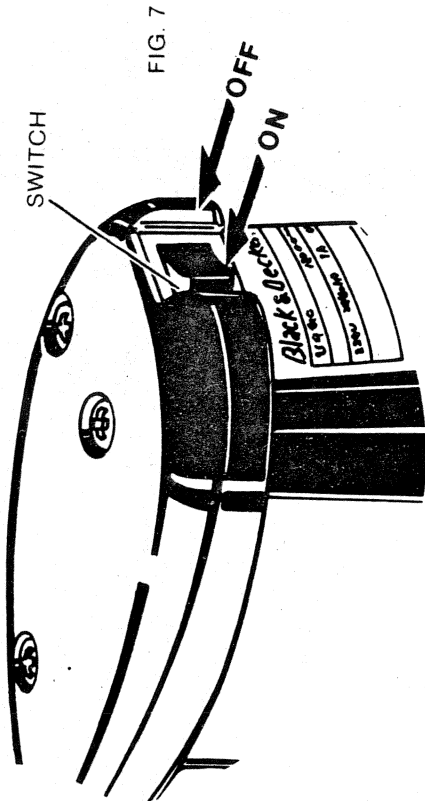

DOUBLE INSULATION

Your Sander is DOUBLE-INSULATED to give you added safety. This means that it is constructed throughout with TWO separate "layers" of electrical insulation or one DOUBLE thickness of insulation between you and the tool's electrical system.

Tools built with this insulation system are not intended to be grounded. As a result, your Drill is equipped with a two-prong plug which permits you to use extension cords without concern for maintaining a ground connection.

NOTE: DOUBLE-INSULATION does not take the place of normal safety precautions when operating this tool. The insulation system is for added protection against injury resulting from a possible electrical insulation failure within the tool.

CAUTION: When servicing Double Insulated Tools USE ONLY IDENTICAL REPLACEMENT PARTS. Repair or replace damaged cords

EXTENSION CORDS

Double Insulated tools have 2 wire cords, and can be used with 2 wire or 3 wire extension cords. Only round jacketed extension cords should be used, and we recommend that they be listed by Underwriters Laboratories (U.L.) (C.S.A. In Canada). If the extension will be used outside, the cord must be suitable for outdoor use. Any cord marked as outdoor can also be used for indoor work.

An extension cord must have adequate wire size (AWG or American Wire Gauge) for safety, and to prevent loss of power and overheating. The smaller the gauge number of the wire, the greater the capacity of the cable, that is 16 gauge has more capacity than 18 gauge. When using more than one extension to make up the total length, be sure each individual extension contains at least the minimum wire size.

To determine the minimum wire size required, refer to the chart below

CHART FOR MINIMUM WIRE SIZE (AWG) OF EXTENSION CORDS								
NAMEPLATE RATING-AMPS	25	50	75	100	125	150	175	200
0-10.0	18	18	16	16	14	14	12	12
10.1-13.0	16	16	14	14	14	12	12	12
13.1-15.0	14	14	12	12	12	12	12	12

Before using an extension cord, inspect it for loose or exposed wires, damaged insulation, and defective fittings. Make any needed repairs or replace the cord if necessary. Black & Decker has extension cords available that are U.L. (C.S.A. in Canada) listed for outdoor use.

MOTOR

Your Black & Decker tool is powered by a B & D built motor. Be sure your power supply agrees with the nameplate marking.

Volts 50/60 Hz or "AC only" means your tool must be operated only with alternating current and never with direct current. Volts DC-60Hz or AC/DC means your tool may be operated with either alternating or direct current.

Voltage decrease of more than 10% will cause loss of power and overheating. All B&D tools are factory tested; if this tool does not operate, check the power supply.

HOLE PUNCH OPERATION

1. Remove the metal guide and the hole-puncher from the paper holder.
2. Place the paper, grain upwards on the holder so that the paper is in contact with the stop.
3. Place the metal guide above the paper so that it is correctly positioned in relation to the holder.
4. With the aid of the holepuncher, make holes by pressing firmly through the guide and the paper.
5. Take out the paper, checking that all the holes are clean and match the sander perfectly.
6. If the holepuncher, after a considerable period of use, produces poor holes, then it is essential to sharpen or replace it.

SAVE THESE INSTRUCTIONS

ATTACHING ABRASIVE PAPER

The 4" sheet Palm-Grip Sander will operate well using either plain abrasive paper or paper punched out for use with the built-in dust extraction feature.

For normal operations, assemble the abrasive paper to your unit as follows:

1. Burnish the reverse side of the abrasive paper over a right angle in order to soften it.
2. Release clamp by pulling up on clamp lever and disengaging it from the tab on the base plate. (See Fig. 1)
3. Insert abrasive paper under the clamp, pull up on lever and lock into place. (Fig. 2)
4. Stretch paper over backing pad and insert under the opposite clamp in the same way.

Should you desire to utilize the dust extracting feature of the tool, simply use perforated paper (available as an accessory item or make your own using template and punch supplied), and assemble in the same manner, making sure the holes in the paper line up with the holes in the base pad. (See "hole punch operation")

Caution: When using perforated paper be sure to remove dust cover (Fig. 6), and install dust recovery bag to insure maximum effectiveness.

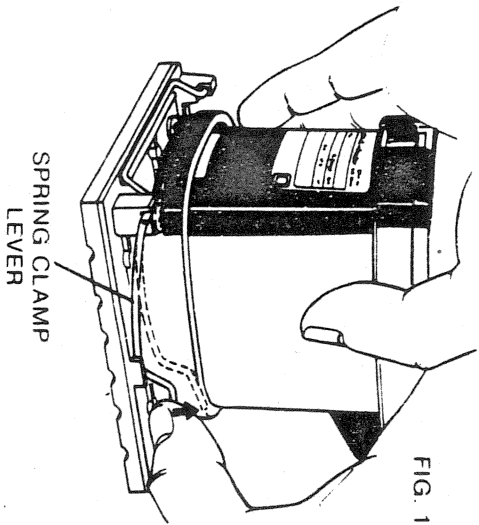

FIG. 1

SPRING CLAMP
LEVER

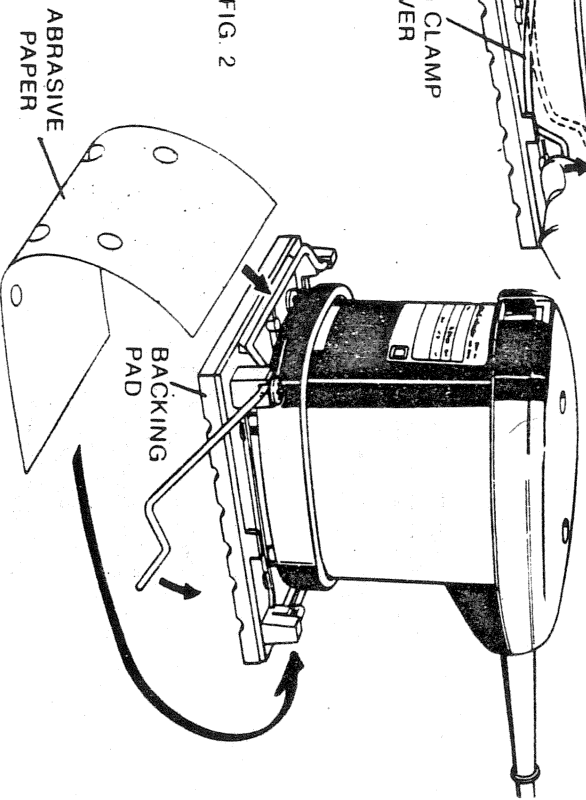

FIG. 2

ABRASIVE
PAPER

BACKING
PAD

DUST RECOVERY BAG

To utilize sander with dust recovery feature, assemble bag as follows:

1. Insert the wire frame into the two holes in the plastic adapter. (Fig. 3)
2. With wire frame attached, insert assembly into dust collecting bag so the plastic adapter protrudes through the opening in the end of the bag, and the wire frame is positioned at the zippered opening. (Fig. 4)
3. Slide assembly into opening located on the cord set side of the sander. (Fig. 5)

NOTE: When not utilizing dust recovery feature, remove bag and opening to avoid getting dust on operator. (Fig. 6)

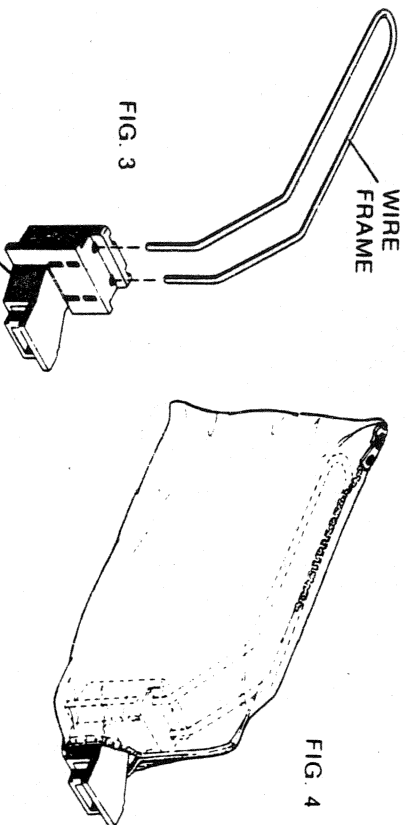

FIG. 3

WIRE
FRAME

PLASTIC ADAPTER

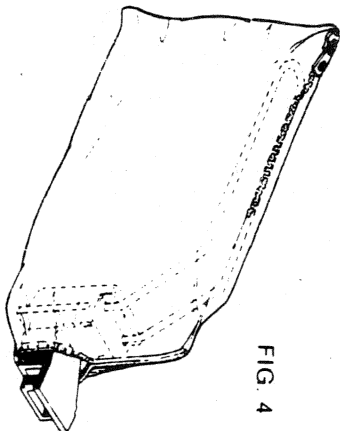

FIG. 4

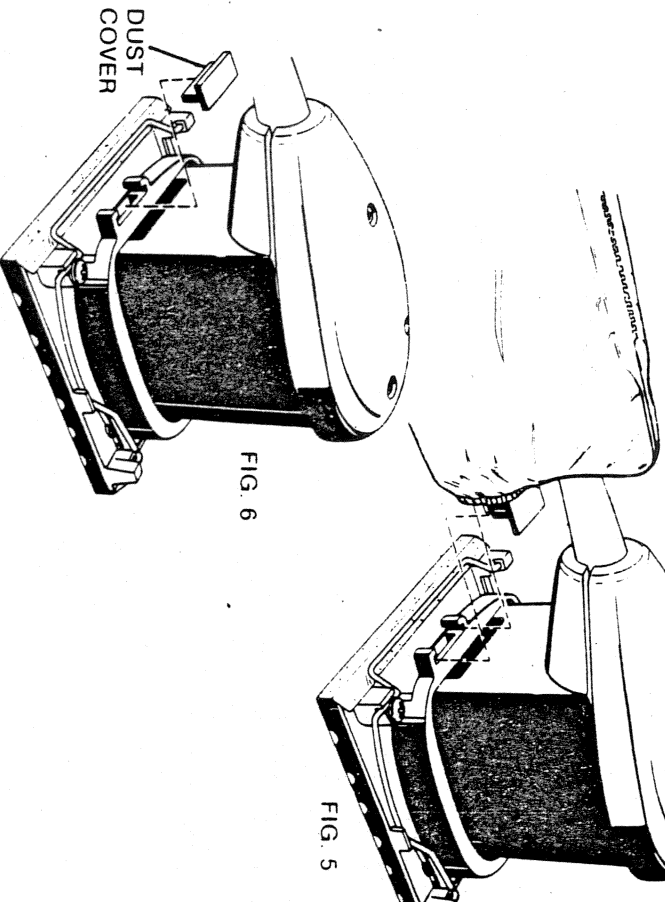

FIG. 5

DUST
COVER

FIG. 6